

T1-PCM-IND

Digital telemetry system for strain gage applications on rotating shafts Operating Instructions



- Easy to assemble and operate
- Strain gage sensors (≥ 350 Ohm)
- Full- and half bridge configuration
- Excitation fixed 4 Volt DC
- Auto-Zero adjustment
- Gain: 250-500-1000-2000 or 1000-2000-4000-8000
- 16 bit ADC
- Digital transmission realized inductively
- Distance up to 30mm (Range)
- Powering of transmitter part inductive
- No influence through radio frequency
- Many systems can operated at the same time
- Signal bandwidth 0...1200Hz (-3dB)
- Output +/-10V
- Output 4-20mA (Option)
- System accuracy $< 0.2\%$

INSTRUCTIONS FOR QUALIFIED PERSONNEL ONLY!

General description

The T1-PCM-IND single-channel telemetry system offers the easiest handling for the wireless transmission of strain gage signals from rotating shafts. The encoder 35x24x14mm with a weight of 16g. The transmitter (encoder) part is simply mounted on the rotating shaft with a special fiber reinforced tape.

The data transfer between transmitter and receiver is digital. The powering of the transmission part by the T1-PCM-IND is **inductive!**.

Functional description

The T1-PCM-IND transmitter provides a pulse code modulated signal (PCM) to an induction winding around the shaft. The magnetic field of this winding enables the inductive transmission of the signal from coil to pickup. From there the signal is transferred by cable (5 m) to the receiver. The maximum distance between the transmitter coil and the pickup/powerhead is 30mm.

The receiver unit offers a BNC connector at the front panel with analog outputs ± 10 V and optional a current output of 4-20mA

Strain gage sensors (≥ 350 Ohm) in full- and half- bridge configuration can be directly connected to the transmitter. The excitation is fixed to 4 Volt DC and the gain is set by plug-In bridge in 4 steps (250-500-1000-2000 or 1000-2000-4000-8000). An auto-zero (AZ) adjustment is executed by pressing the AZ button on the front side of the receiver. The successful AZ operation is indicated by a yellow LED. The yellow LED flashes as long as the AZ is in progress. When the AZ completes the LED continuously illuminates. The AZ setting is stored in a Flash-RAM and thus is not lost during power-off.

T1-PCM-IND set contains:

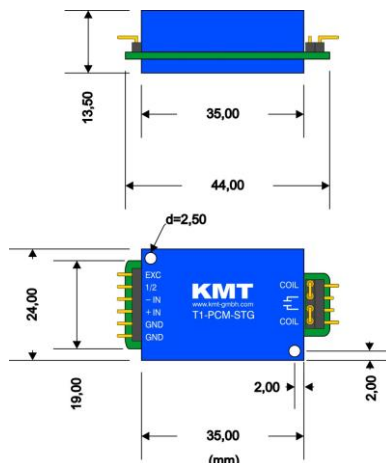
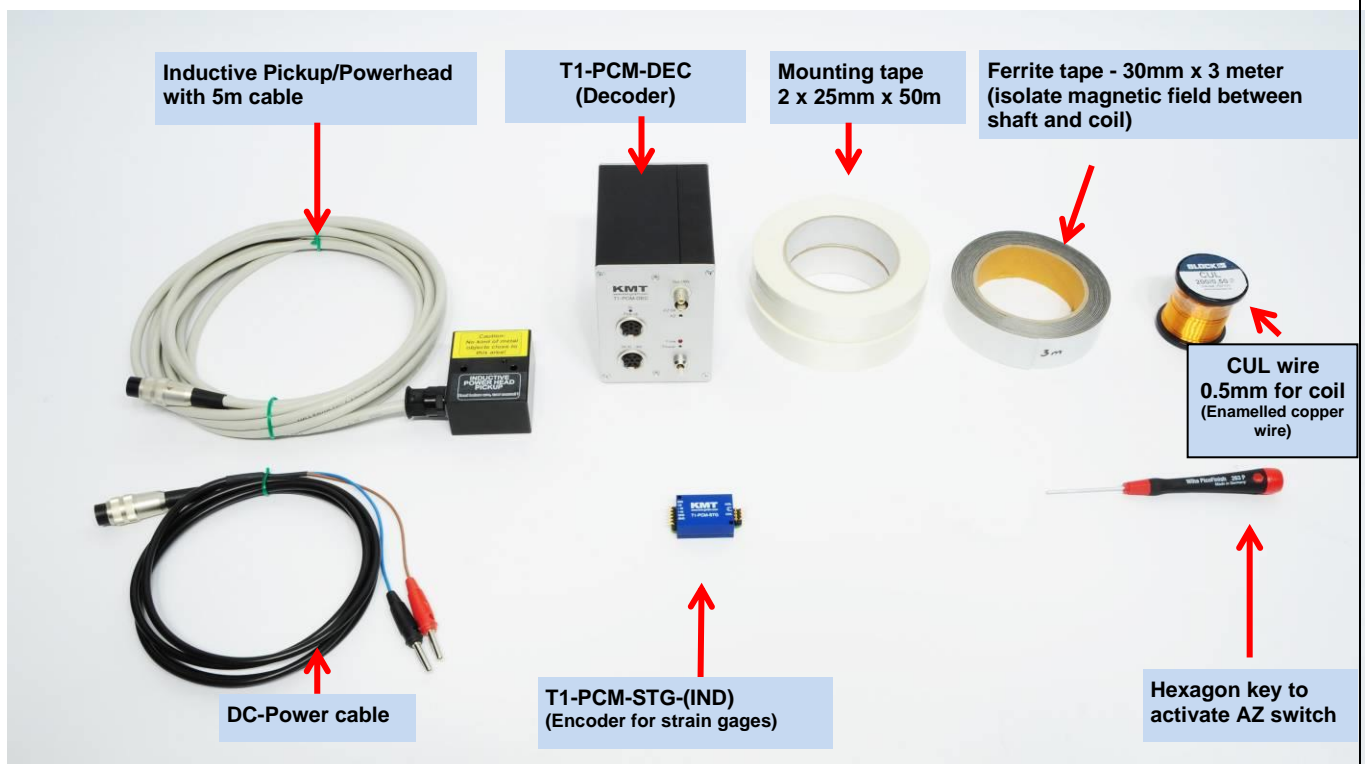

Technical data transmitting part:

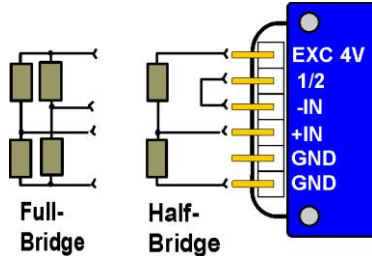

T1-PCM-STG

Strain gage: Full and half bridge $\geq 350 \text{ Ohm}$,
 Excitation: 4 VDC (fixed)
 Gain: 250-500-1000-2000 standard
 1000-2000-4000-8000 **on request!**

Gain and Sensitivity

Gain 250 = +/-10mV/V	Gain 2000 = +/-1.250mV/V
Gain 500 = +/-5mV/V	Gain 4000 = +/-0.625mV/V
Gain 1000 = +/-2.5mV/V	Gain 8000 = +/-0.3125mV/V

AZ: Auto Zero calibration (via AZ button from receiver side)
 Analog signal bandwidth: 0 - 1200 Hz (-3 dB)
 Operating temperature: - 40 to + 85 °C
 Resolution 16bit
 Scanning rate 6.41 kHz
 Powering: inductive
 Dimensions: 35x24x14mm, weight 16g
 Housing: splash-water resistant IP65 (except the connector pins)



T1-PCM-Pt100

Pt100 thermo sensor
 Measurement range -50 to 250°C or -50 to 500°C (select by jumper)
 Analog signal bandwidth: 0 - 10 Hz (-3 dB)
 Operating temperature: - 40 to + 85 °C
 Resolution 16bit
 Scanning rate 6.41 kHz
 Powering: inductive
 Dimensions: 35x24x14mm, weight 16g
 Housing: splash-water resistant IP65 (except the connector pins)

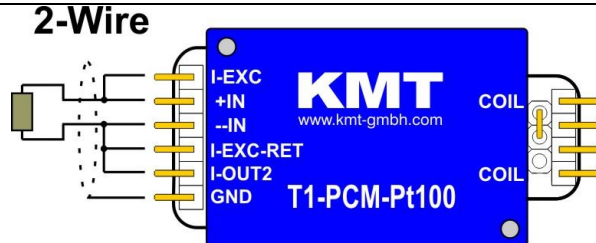
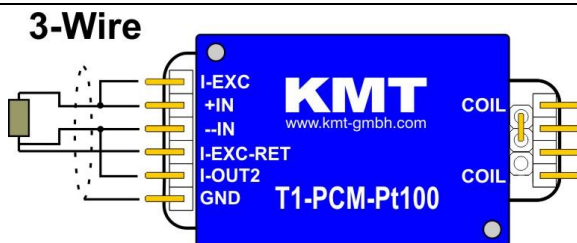

Common characteristics / Environment
 (rotating parts)

Vibration (random): 0.05 g²/Hz (20 Hz to 2 kHz)
 Vibration (sine): 10 g (20 Hz to 2 kHz)
 Shock (½ sine): 500 g peak (11 ms)
 Static Acceleration: 3000 g (depends on mounting!)
 Operating temperature: -40 to +85°C
 Humidity: 95 % (not condensing!)

Dimensions Encoder - T1-PCM-STG

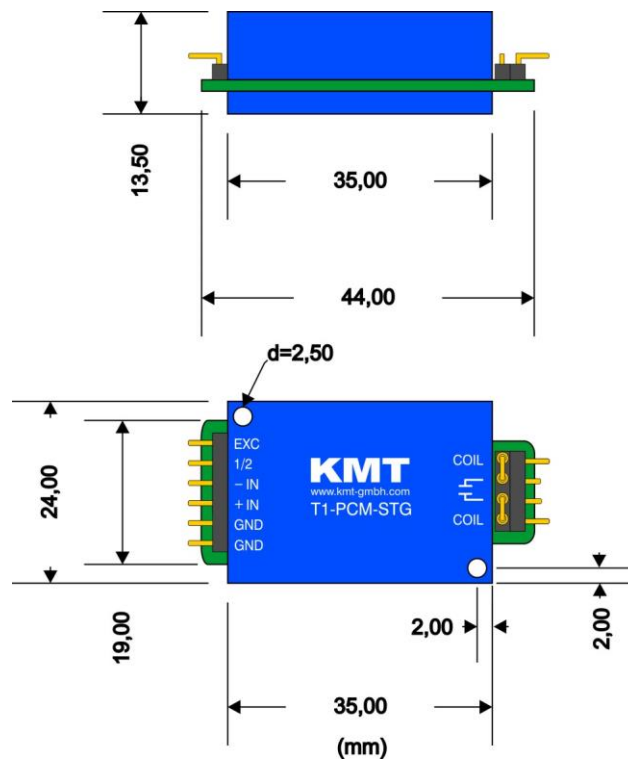

Draw about 1:1

Weight 16 gram

Technical data receiving part

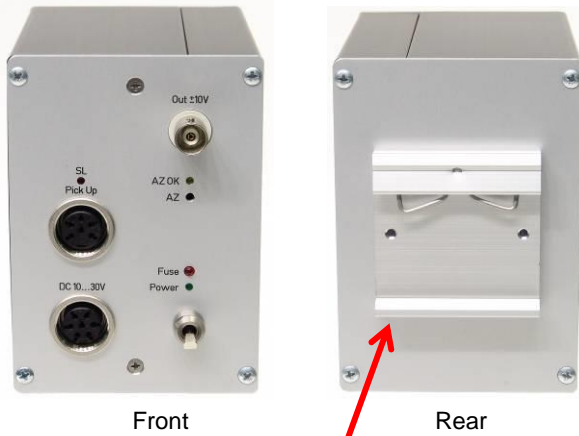

Optional top-hat rail clip

T1-PCM-DEC

Analogue output: +/-10V via BNC output 1200Hz
(delay between analog IN/OUT 1.8mS constant!!)
Optional add. 4-20mA output to the analog output
 Auto Zero setting: via AZ button
 Autozero LED:
 Yellow ON- successful AZ
 Yellow OFF- not successful AZ
 if flashing, call support of KMT, error in EPROM
 SL LED: Red ON = if error of data transmitting
 SL LED: Red Flashing = distance to far
 Power ON LED: Red ON = if power switch on
 Output to Powerhead: via 6-pol. Tichel
 Fuse LED: Flashing if fuse is defect
 Powering: 10-30V DC (min. 24Watt), Input via 7-pol. Tichel
 Switch: ON/OFF
 Operating temperature: - 40 to +70 °C
 Dimensions: 75 x 105 x 105 (without connectors!)
 Weight 750 grams
 Static acceleration: up to 200g
 System accuracy*: +/- 0.2 %
 < *measure with gain 1000, 350ohm (0.1%) full bridge - test bridge! >



T1-PCM-Pickup/Powerhead (standard version)

Function: Receiving inductive PCM modulated data from the coil of the T1-PCM-STG unit
Inductive frequency is 60kHz
 Distance between the transmitter coil and the pickup is 5-30*mm
 Output to T1-PCM-Decoder: Via 6-pol. Tichel plug incl. 5m cable
 Operating temperature: - 40 to +85 °C
 Dimensions: 53x66x30mm (without cable)
 Weight: 200 grams (without cable!)
 Housing: splash-water resistant IP65 (except connector).
 Cable length standard 5m! Optional 10 or 15m

*(depend of shaft diameter!)

Pin connection & block diagram

At high RPM we recommend to solder the GAIN jumper! On the back side of PCB are solder bridges what can use instead of jumper!

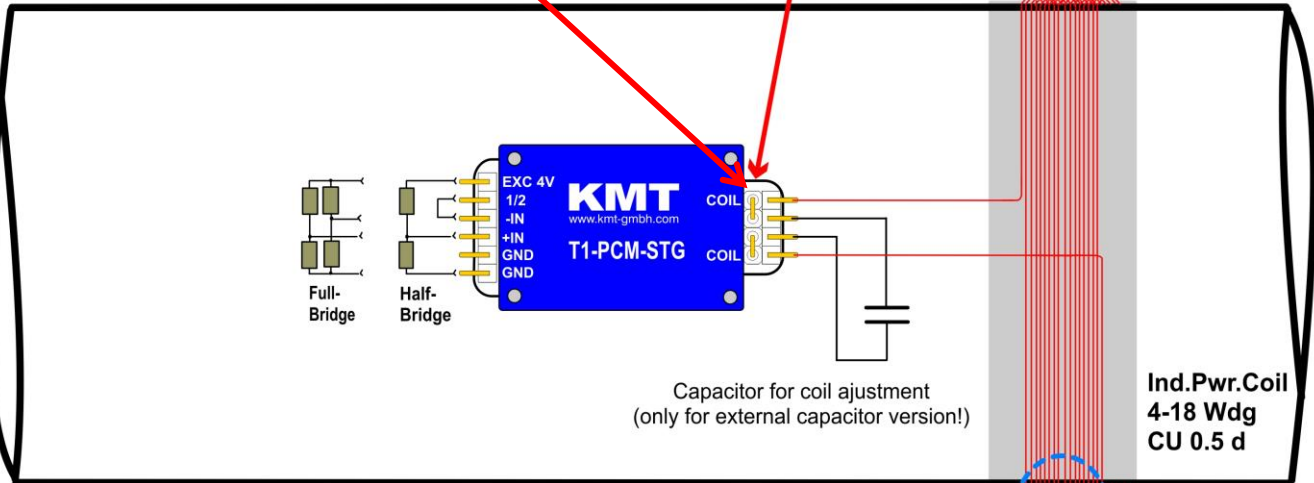
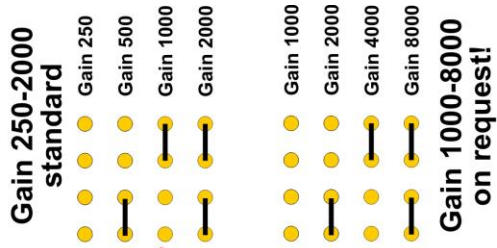

Distance up to 5-30mm

Magnetic field

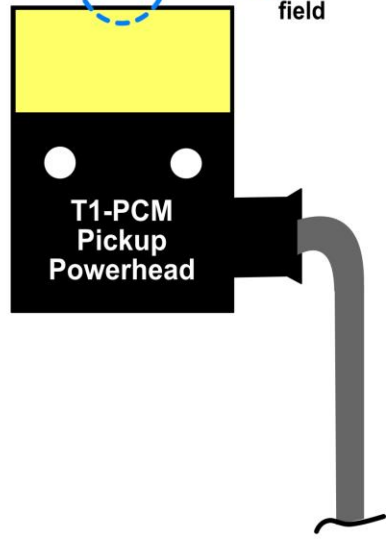
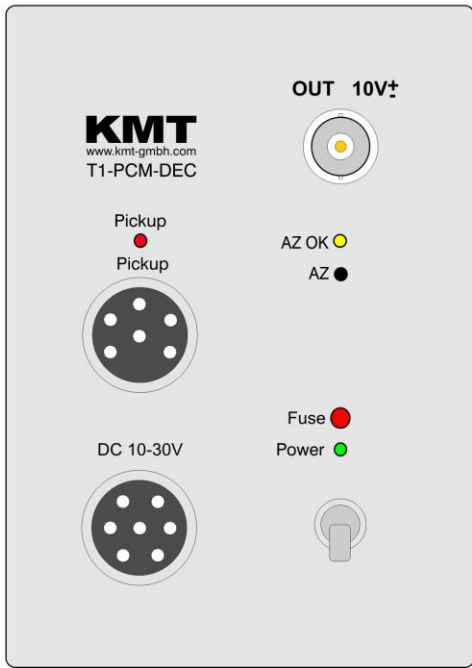

Digital data transfer

Caution:

The Powerhead must be fixed in the middle of the coil in a distance from 5 to 25 (35)mm.

Don't introduce any metal parts between or near the Powerhead and the shaft.

Don't mix T1-PCM and Tel1-PCM parts together!

There are not compatible!

Mounting example of power head / pickup:

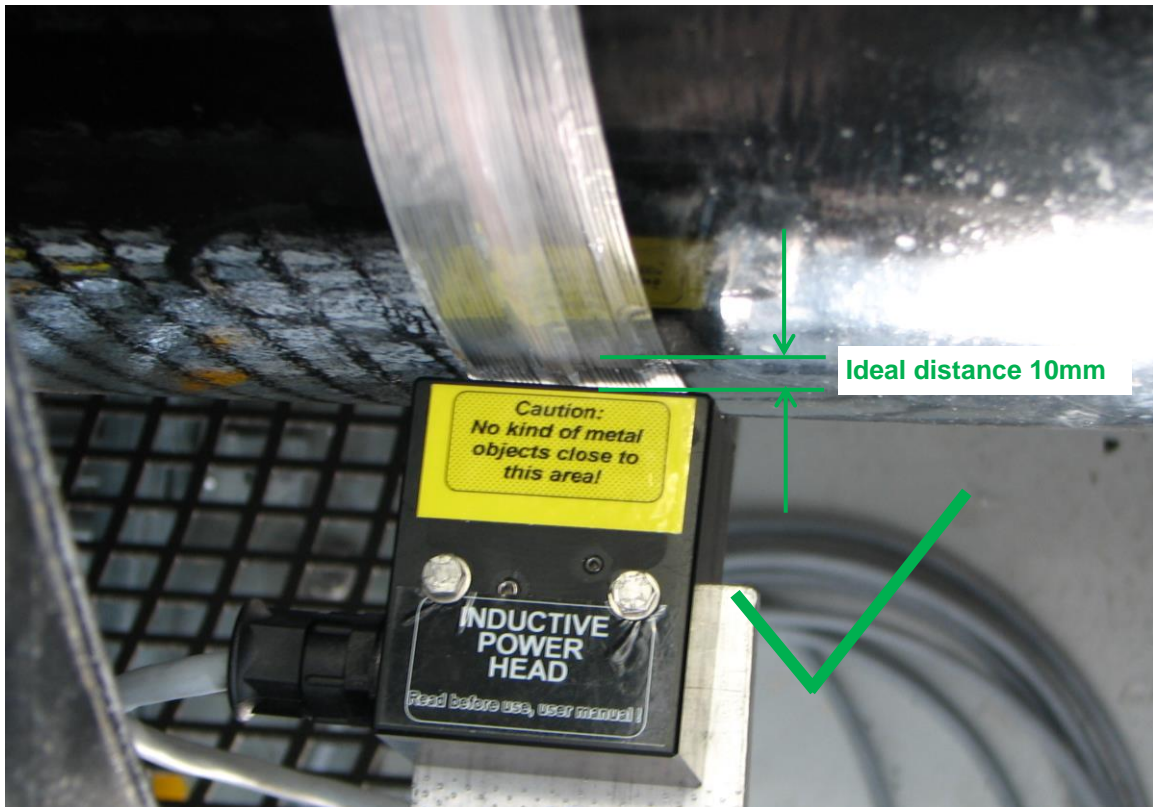

Right installation



Wrong installation, head position is 90° wrong to the coil and will not work!

Receiving part:

Front

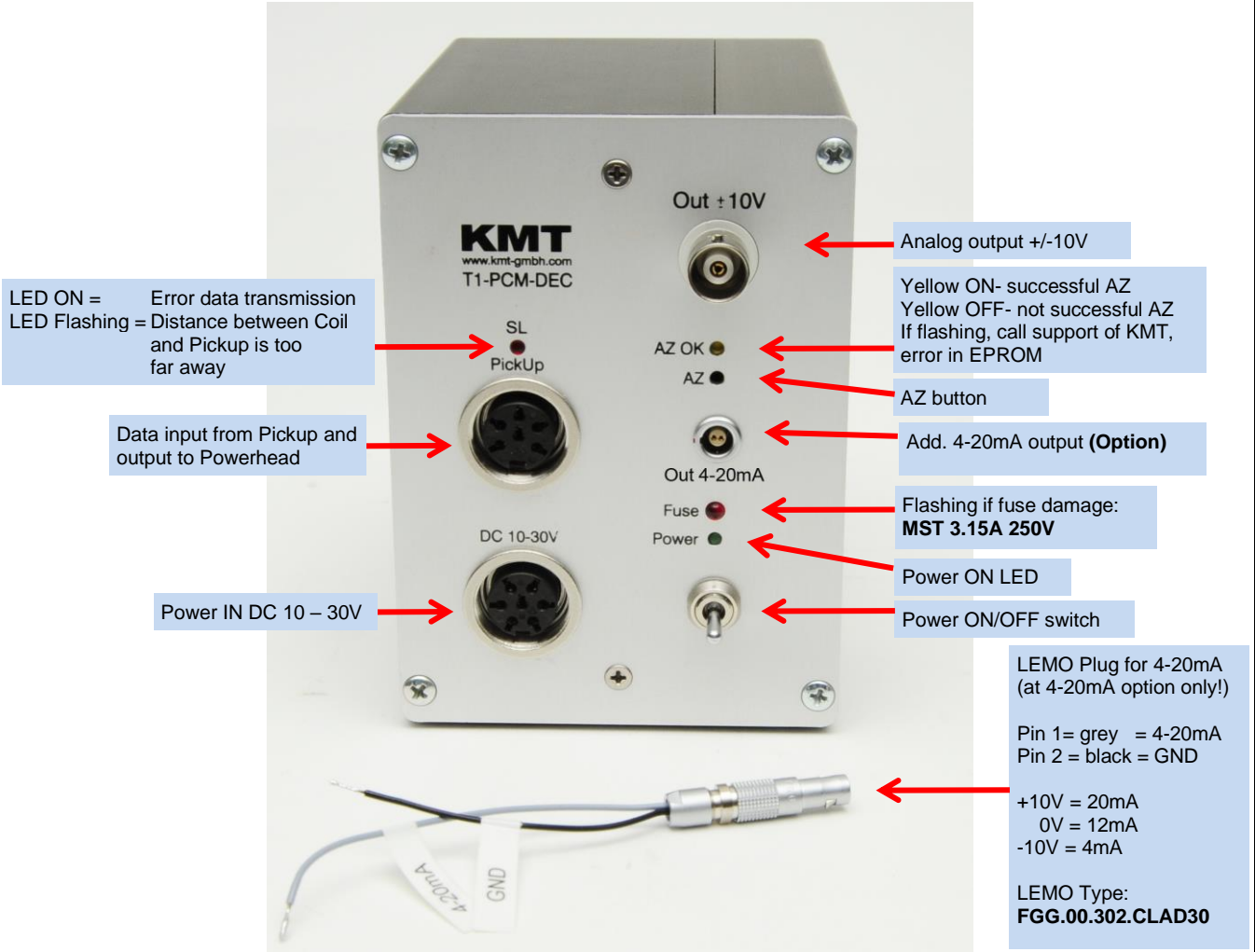

Rear



Receiving part - dimensions:

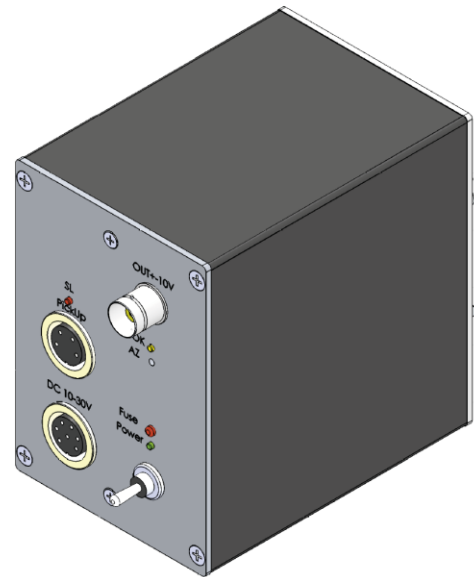
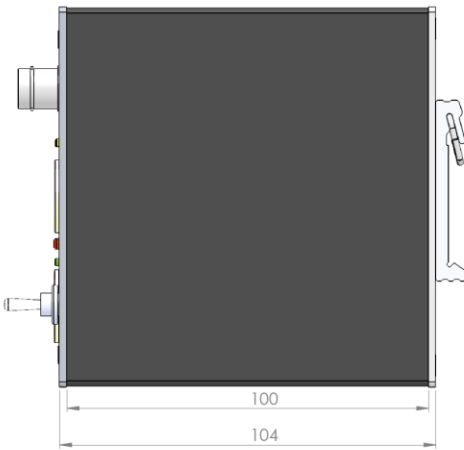
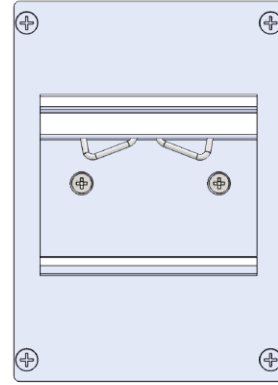
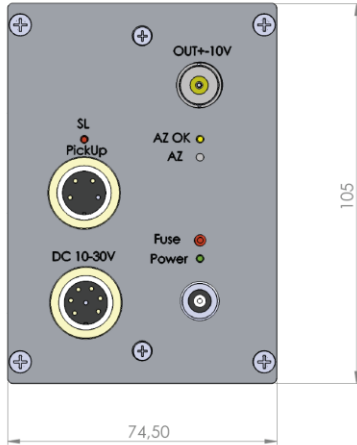

Weight: 0.750 kg

Pin connection cable:

Pickup / Powerhead

Standard version for distance of 5-30*mm
 *(depend of shaft diameter!)

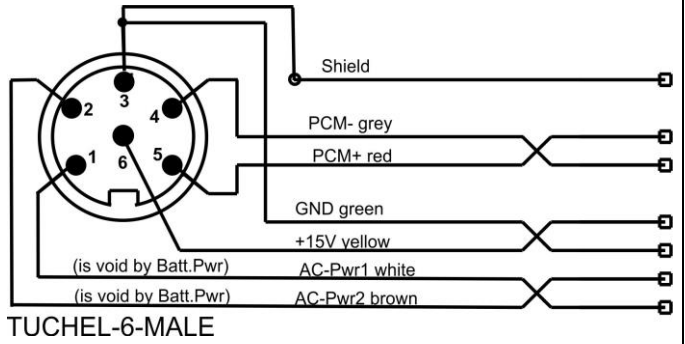

DC-Power cable

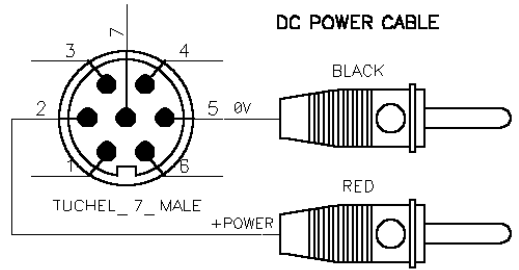

Shaft installation

2 layers (layer by layer) of the special ferrite tape around the shaft

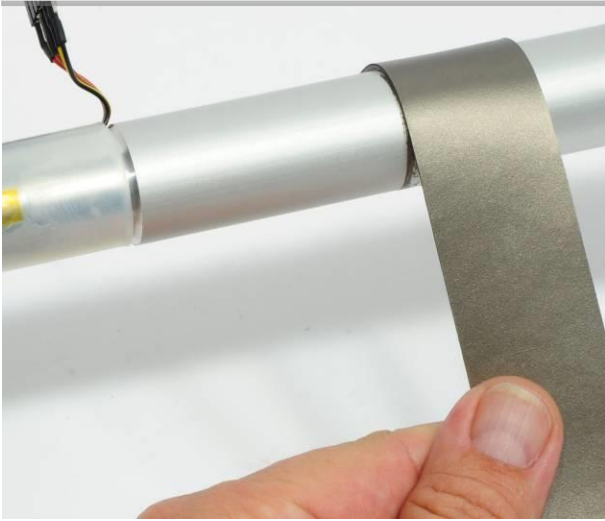

Fix with 2 layers of mounting tape around the shaft

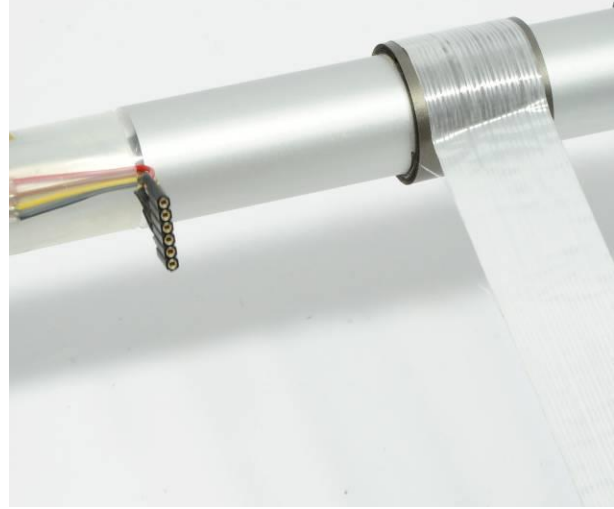

Coil, depends of shaft diameter 5-18 parallel windings of 0.5 CUL (Enamelled copper wire) wires, see table for help.

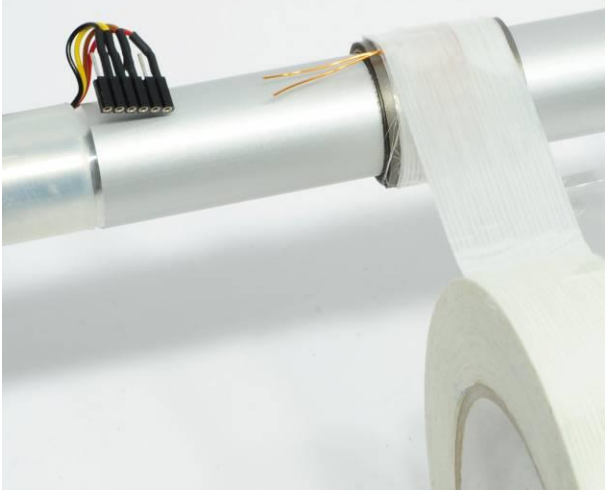

Fix with 2 layers of mounting tape around the coil



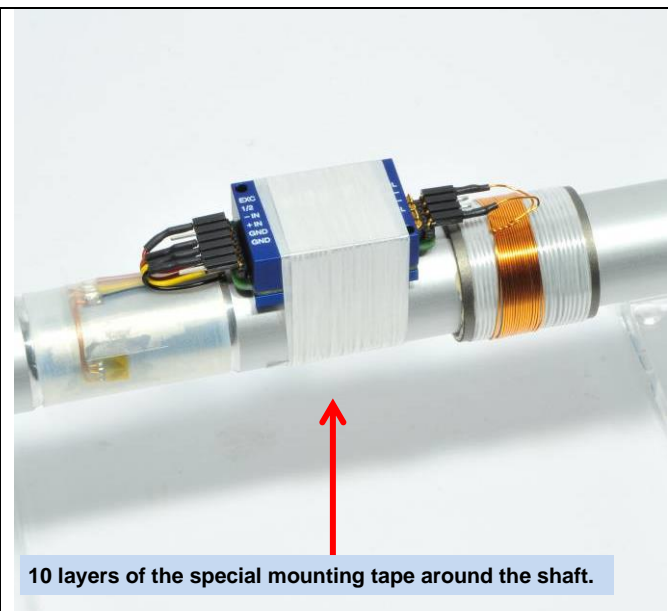
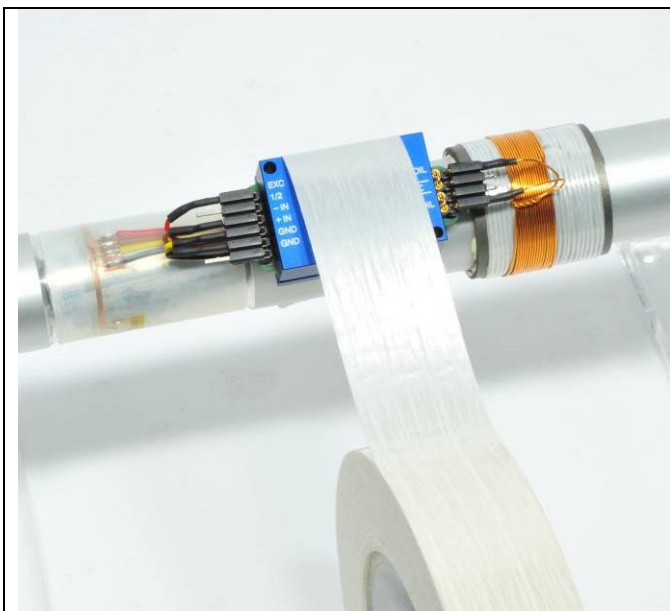

10 layers of the special mounting tape around the shaft.



We recommend add. use a steel hose clamps for final fixing!!

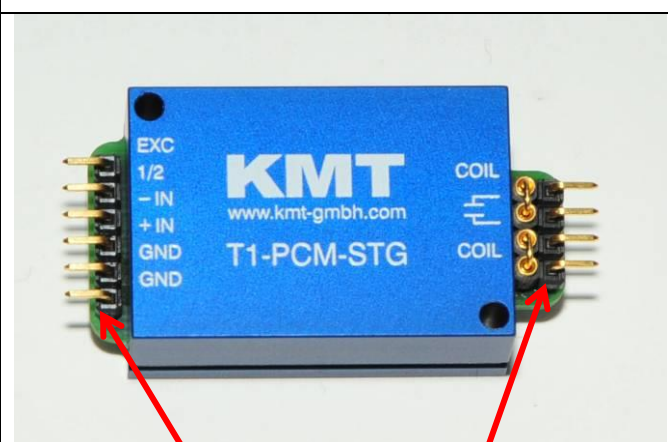

We recommend soldering all pins of the T1-PCM-STG!

Caution:

Fix T1-PCM-STG module with at least 10 layers of the special mounting tape around the shaft. Depending on the shafts RPM and diameter particular attention needs to be paid to the safe mounting of the components.

The manufacturer doesn't accept liability for damages, which results from insufficient attachment of the individual components.

The tape is only for test purposes, in order to test the electrical function of the units in the idle state of the shaft.

During the rotation test appropriate safety precautions should be taken.

The entire installation may be used only by authorized persons. By using tape for the attachment, it has to be used in the direction of rotation of the shaft and the end has to be secured. Only non-elastic tapes with high tensile strength should be used for pre-fixing. Additionally, use hose clamps for final fixing!! The individual components are to be distributed in such a way on the shaft that imbalances are avoided.

Find the correct amount of windings

The number of windings depends on several factors. The most important influential factors are the diameter, the material of the shaft and the environment around the shaft. The table standing below will help you to find the right number windings for steel shafts. The table below is a help to estimate the number of windings fast. To optimize your results you can try one winding more or less.



Coil, depends of shaft diameter 5-18 windings of 0.5 CUL wire

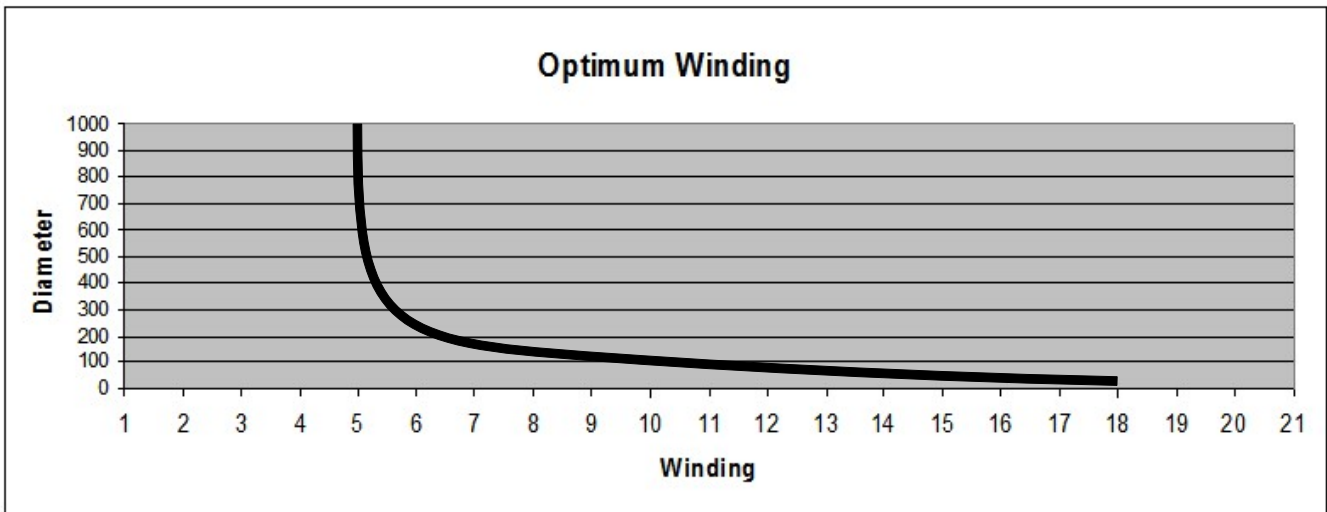

Diameter (mm)	Windings (+/-1)	max. distance with (30mm) Powerhead	Ferrite tape no. of layers	recommend capacitance (Type MKT or MKS 250V)
1000	5	10mm	2	without built-in 220nF, only with external 68nF (specify at order)
500	5	18mm	2	without built-in 220nF, only with external 100nF (specify at order)
500	3	5mm	2	with built-in 220nF (is standard in housing) Not recommend for large diameters!!
300	5	22mm	2	with built-in 220nF (is standard in housing)
210	6	23mm	2	with built-in 220nF (is standard in housing)
160	7	23mm	2	with built-in 220nF (is standard in housing)
130	8	30mm	2	with built-in 220nF (is standard in housing)
90	11	30mm	2	with built-in 220nF (is standard in housing)
60	13	30mm	2	with built-in 220nF (is standard in housing)
30	14	30mm	2	with built-in 220nF (is standard in housing)
20	18	30mm	2	with built-in 220nF (is standard in housing)

Take note:

The typical distance between powerhead and coil is about 10mm!

At 10mm you have the lowest power consumption at the T1-PCM-DEC.

(At 5mm additional inductive power will flow in to the steel shaft and the T1-PCM-DEC will warm up!)

You can check it easy with an ampere meter at the power input of decoder!

Typical power consumption e.g. at 12V = 0.9-1.0A

T1-PCM-IND

Following must be considered at the mounting of the inductive power head

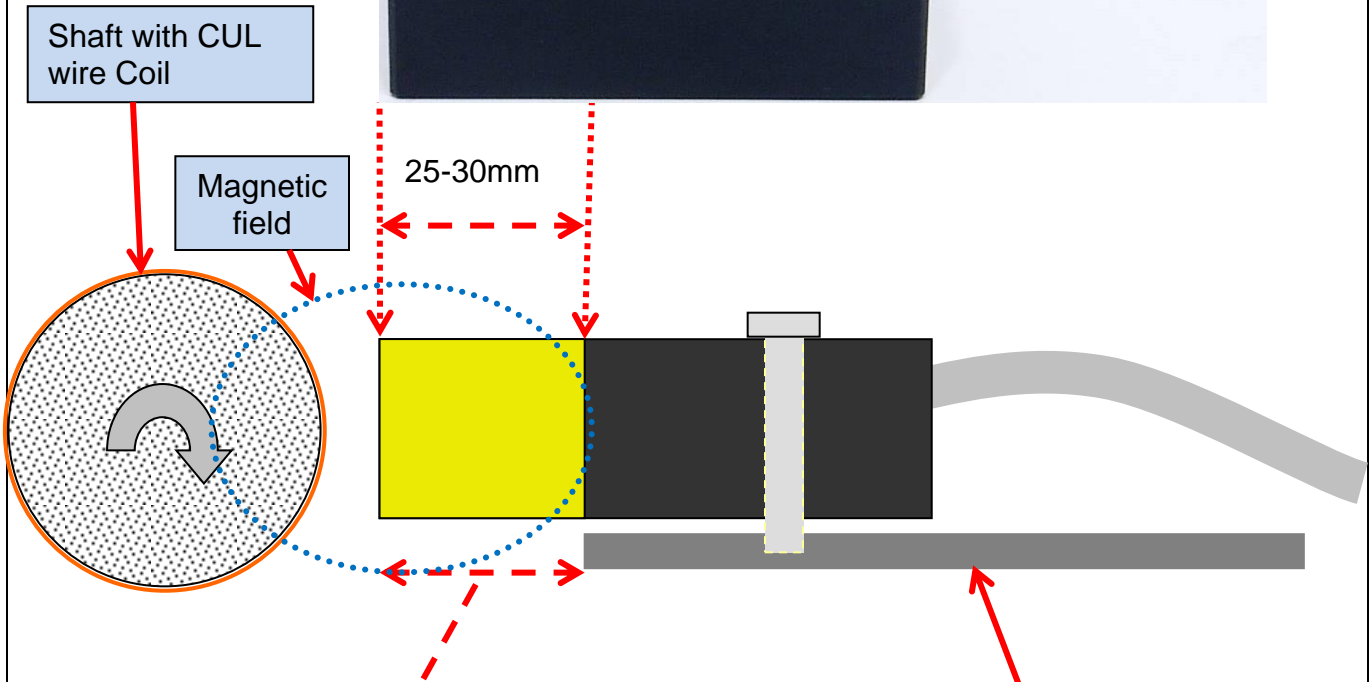

Don't use for mounting any kind metal in this area (25-30mm)! Otherwise magnetic energy will flow in the metal and decrease the distance between power head and coil (on shaft)!

Example of mounting

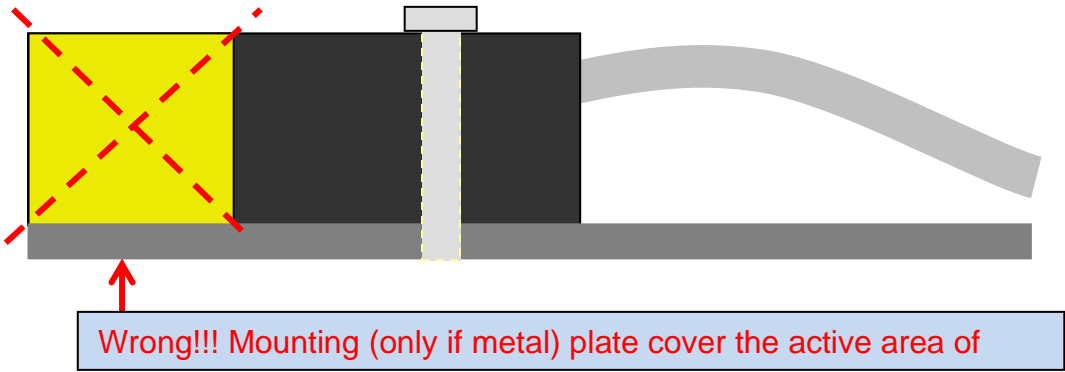

Powerhead / Pickup - distances (coil / head)

PH-PU-Standard & XL

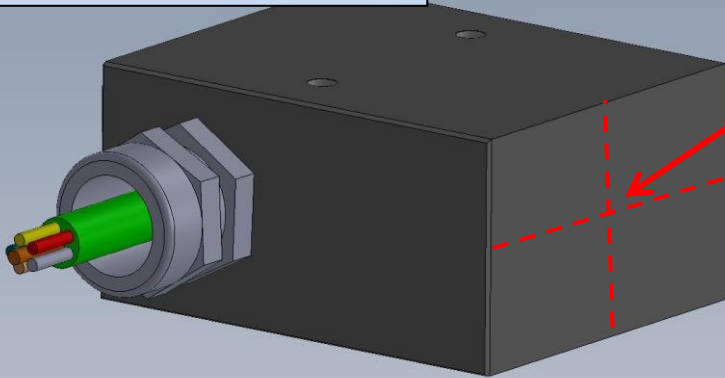

From center cross out

+/-10mm Z

+/-10mm Y

10-25mm standard,
at XL 10-35mm X

PH-PU-N25

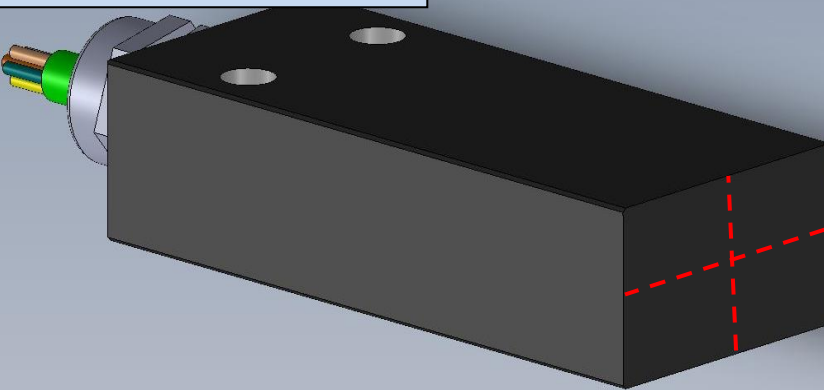

+/-10mm Z

+/-10mm Y

10-25mm X

PH-PU-XL100Z

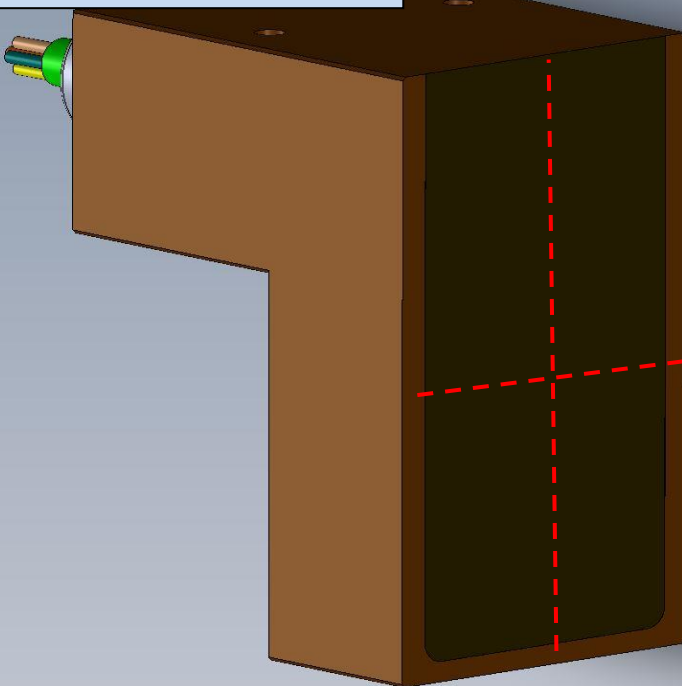

+/-50mm Z

+/-10mm Y

10-30mm X

All distance are only „up to“ and can change a little, depends of diameters!
(typical shaft diameter 20-50mm)

Dimensions Powerhead / Pickup

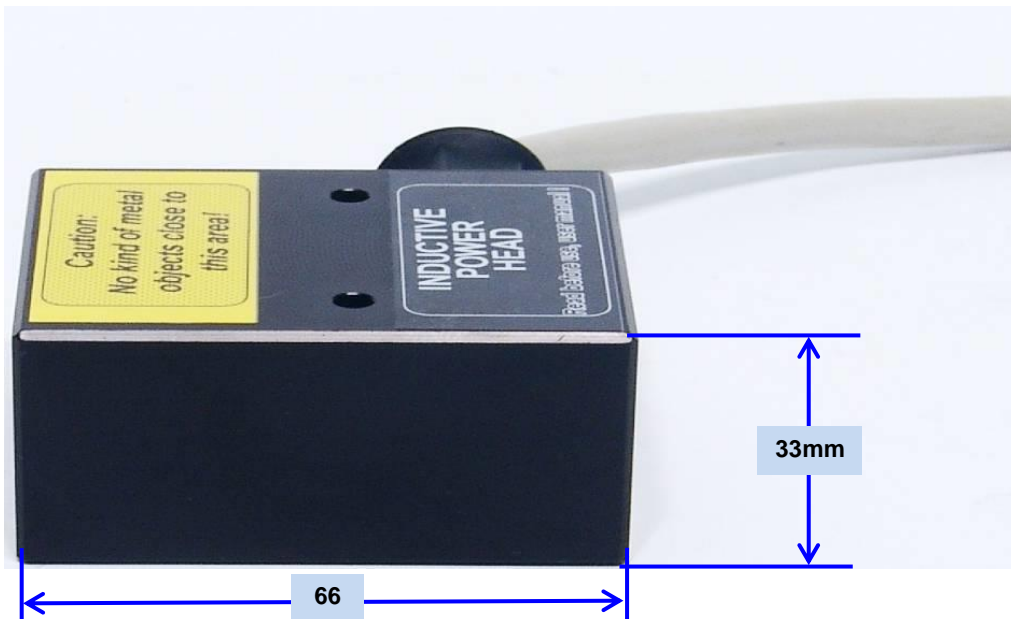
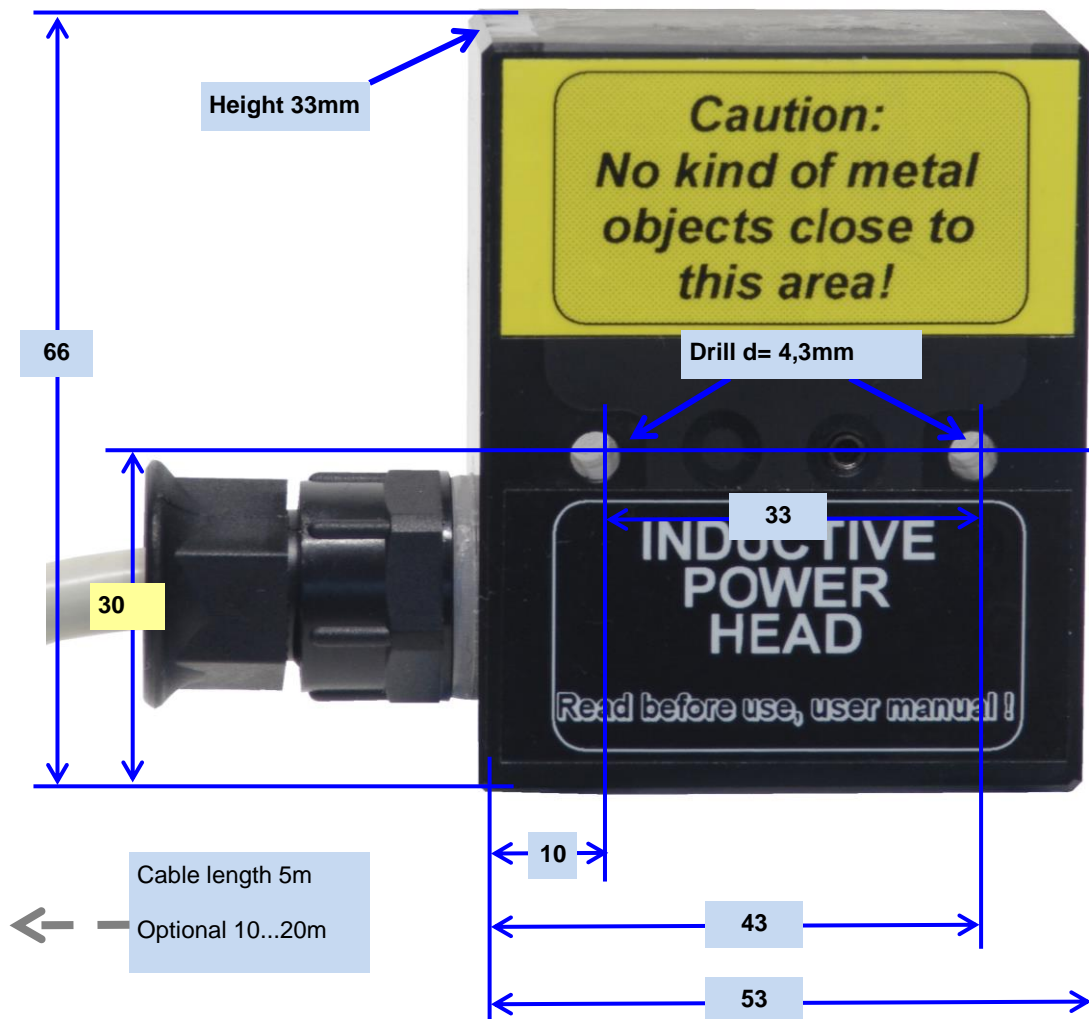

Dimensions Powerhead / Pickup (Standard and XL) draw

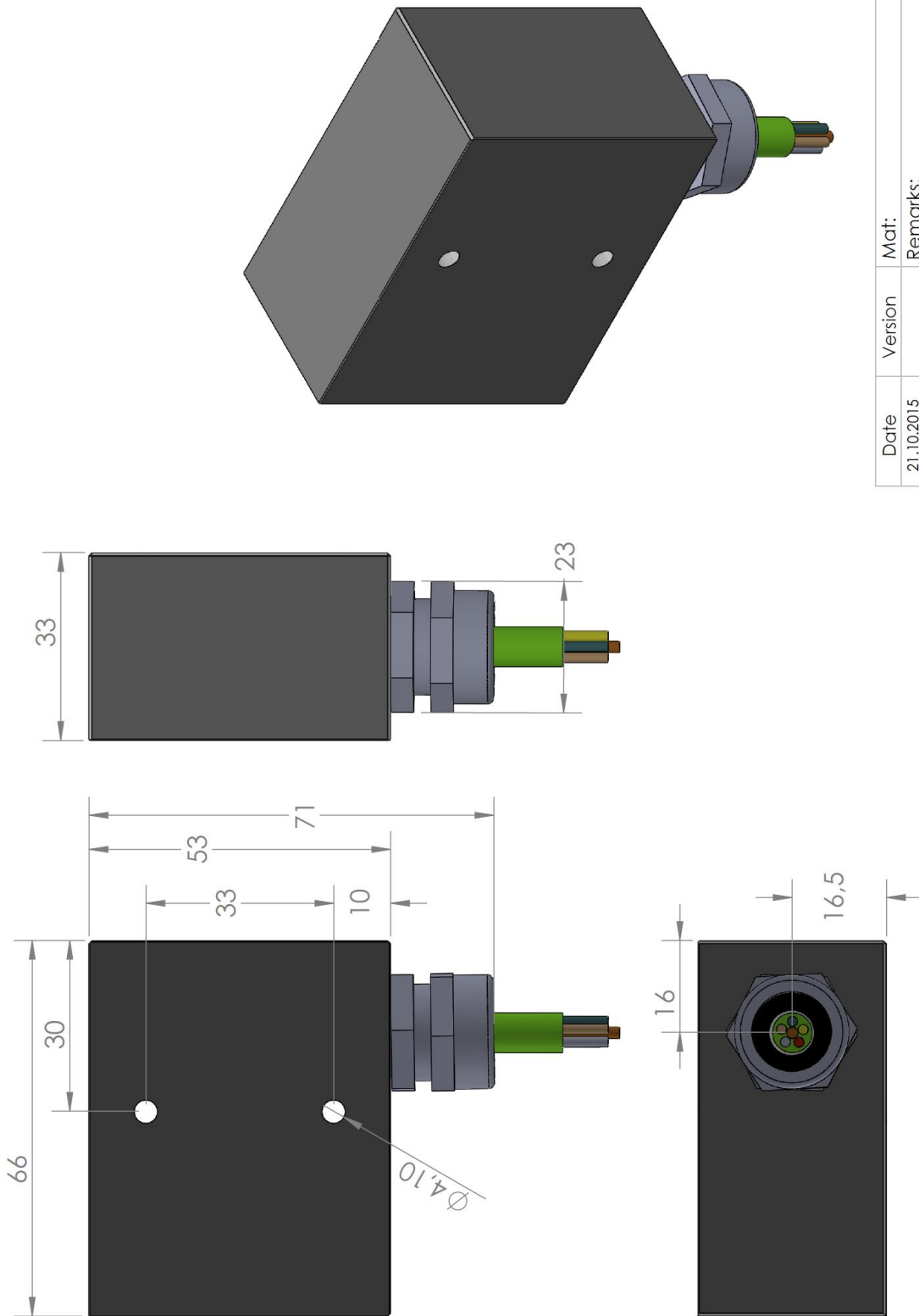

Date	Version	Mat:
21.10.2015		Remarks:
		Bl : A4 Weight-gr:
		Scale
		Part:
		1:1 TEL1-PCM-PHPU
		www.kmt-telemetry.com
		E-mail: info@kmt-telemetry.com
		Tel: +49 8024-48737, Fax: +49 8024-5532
KMT		hu
TELEMETRY		

Dimensions Powerhead / Pickup (CRS at standard and XL) draw

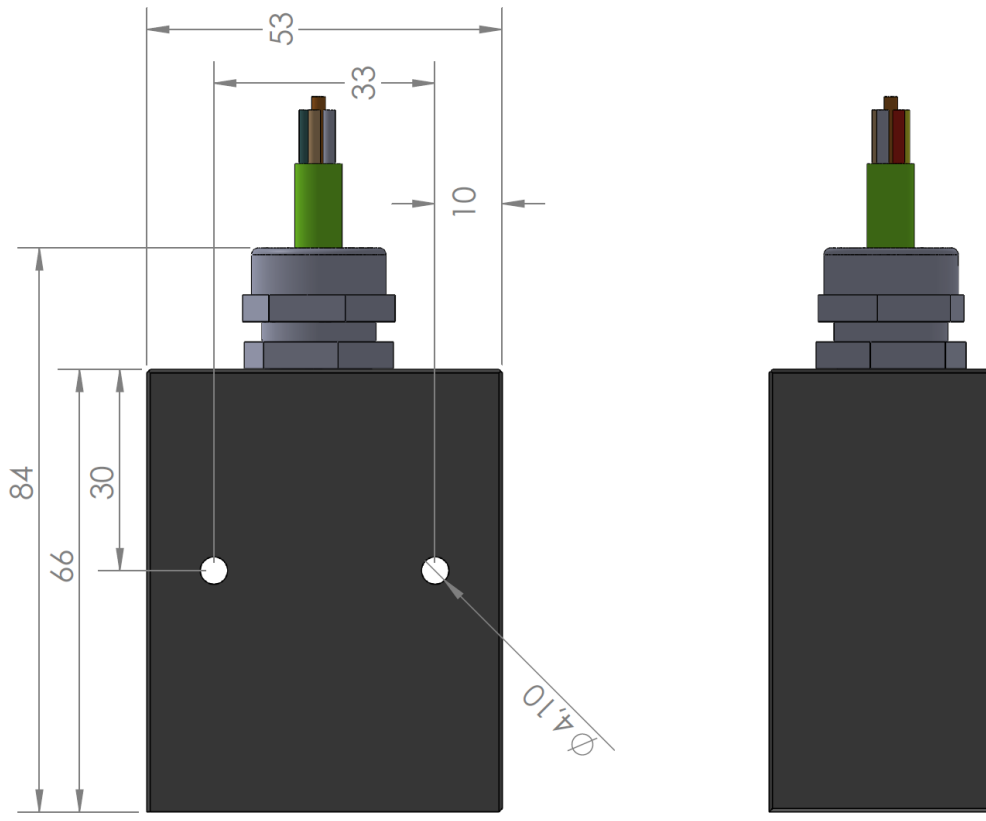
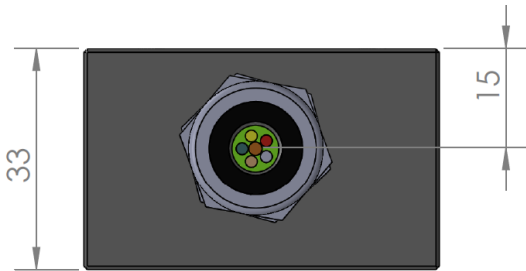
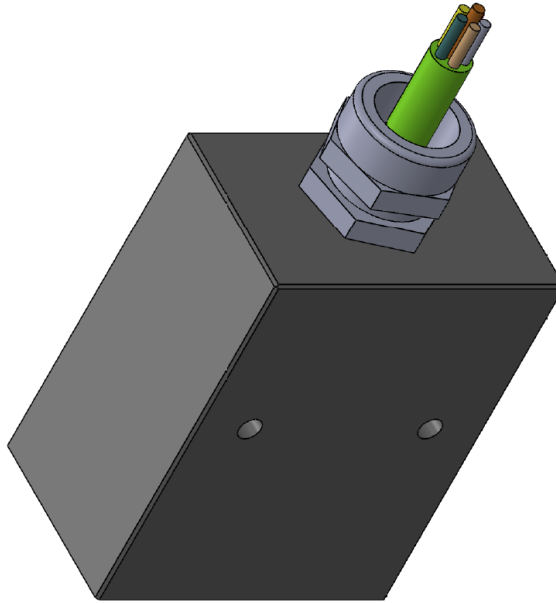

Date	Version	Mat:
21.10.2015		Remarks:
		Bl: A4 Weight-gr:
		Scale
		1:1
		Part:
		Te11-PCM-PHPU-CRS
		www.kmt-telemetry.com
		E-mail: info@kmt-telemetry.com
		Tel: +49 8024-48737, Fax: +49 8024-5532



CRS = cable rear side out!

Dimensions Powerhead / Pickup (N25) draw

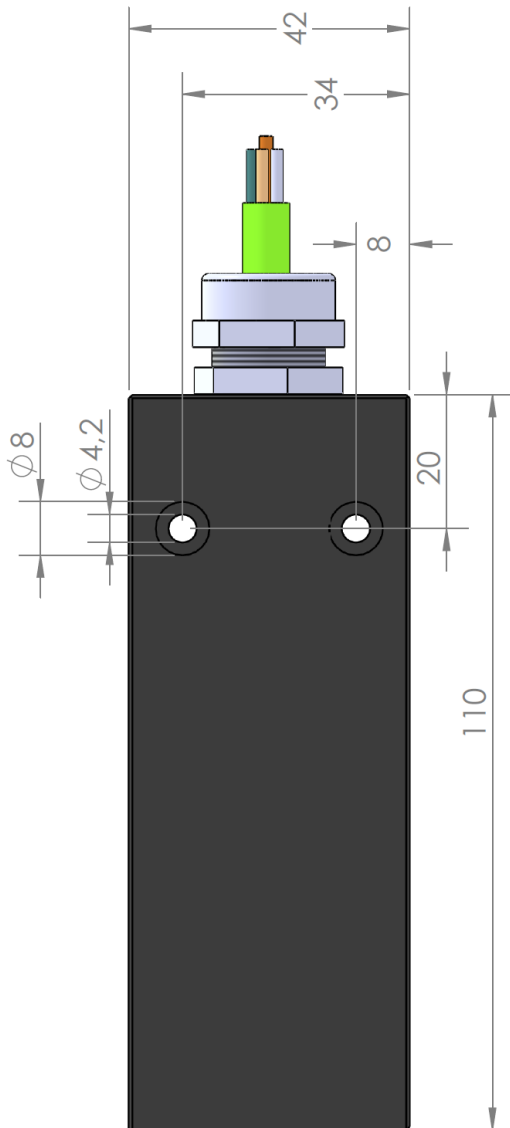
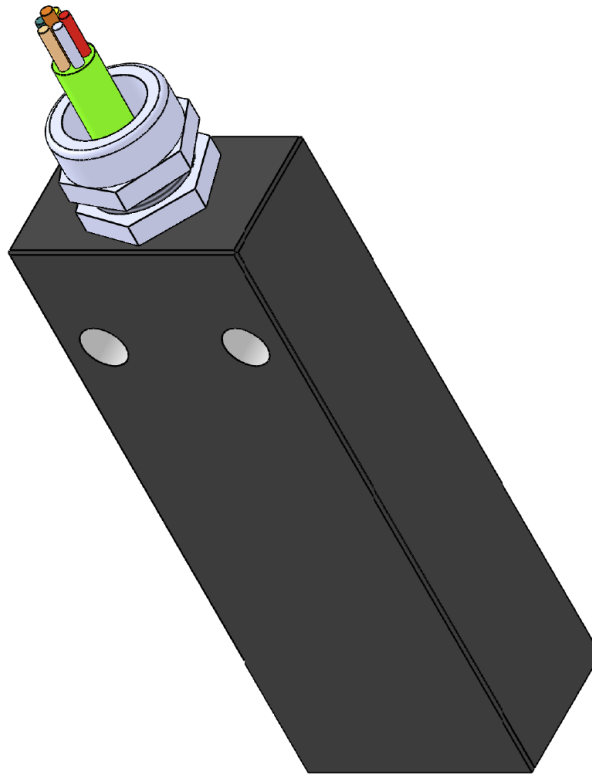
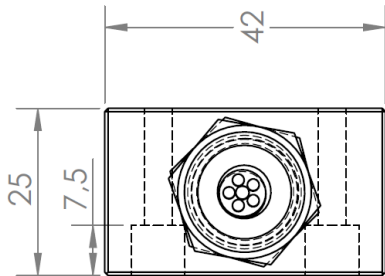

Date	Version	Mat:
21.10.2015		
Remarks:		
Bl: A4 Weight-gr:		
Scale		
1:1		
Part: Te11-PCM-PHPU-N25		
www.kmt-telemetry.com		
E-mail: info@kmt-telemetry.com		
Tel: +49 8024-48737, Fax: +49 8024-5532		
KMT		
TELEMETRY		
hU		

Dimensions Powerhead / Pickup (XL100-Z) draw

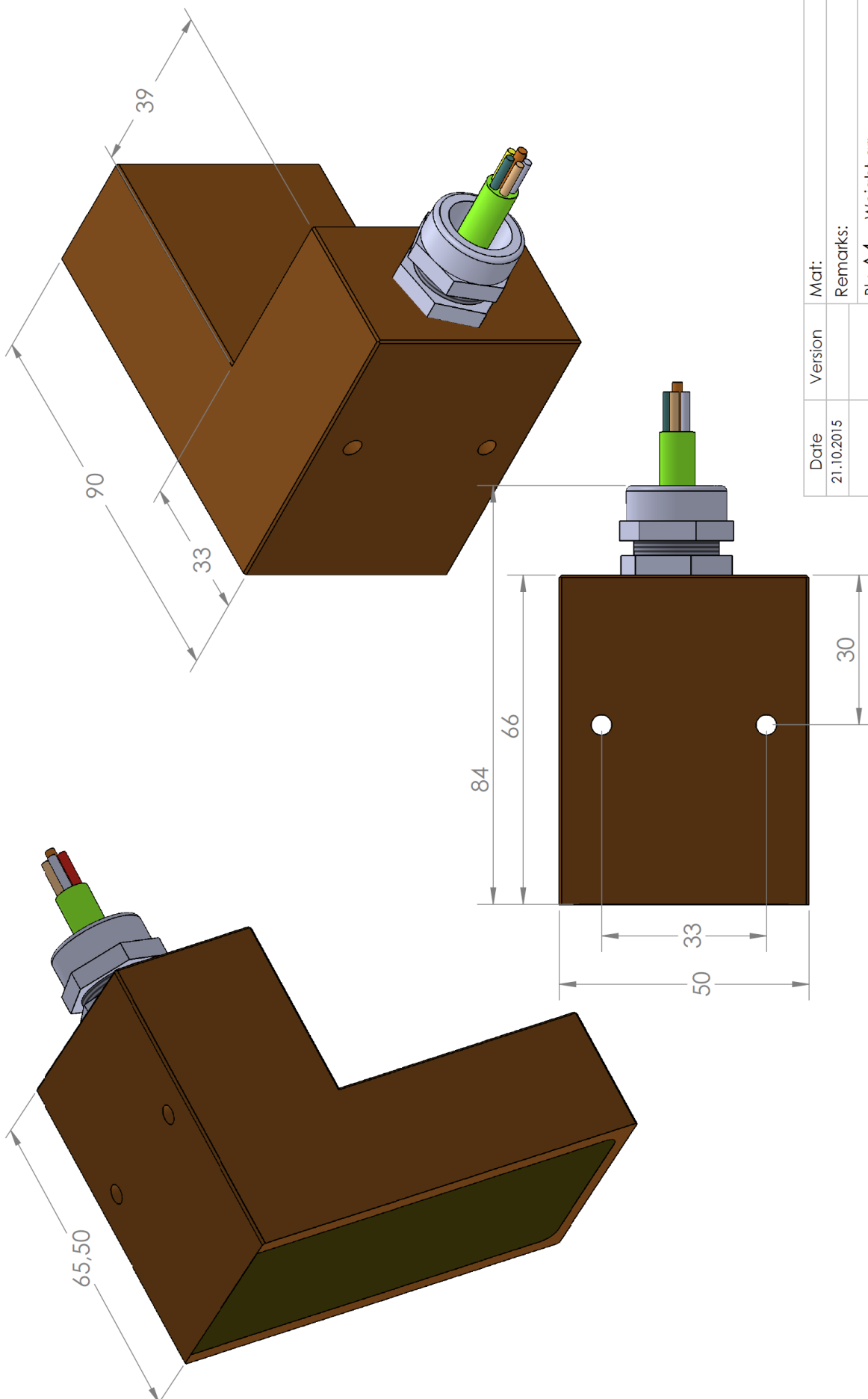

Date	Version	Mat:	Remarks:
21.10.2015		Bl : A4	Weight-gr:
KMT TELEMETRY		Scale	Part:
		1:1	Tel1-PCM-PHPU-XL100
		hU	E-mail: info@kmt-gmbh.com Tel: 08024-48737, Fax: 08024-5532

Dimensions Powerhead / Pickup XXL draw

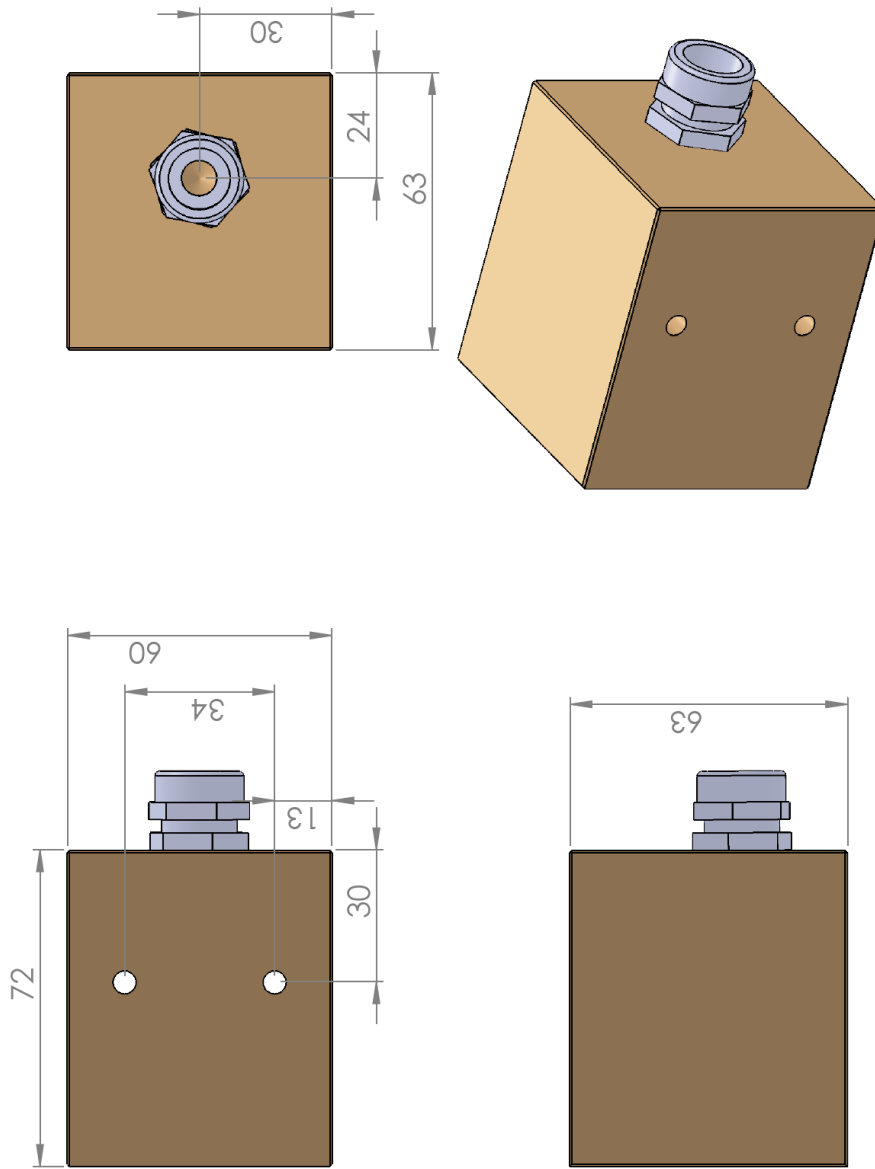

Date	Version	Mat:
23.03.2017		
Remarks:		
Bl: A4	Weight-gr: 351.47	
Scale	Part:	
1:1.5	PHPU-n_XXL-bg	
E-mail: info@kmtgmbh.com		
Tel: 08024-48737, Fax: 08024-5532		
KMT		
TELEMETRY		hu

Attention

- Use only shielded sensor cable
- When used on rotating shafts, all connections must be soldered.
- Mounting of the modules on a shaft must be first fixed with mounting tape (only for prefixing) and then with a [hose clamps!!!](#)



Safety notes for inductive powering

- The device should only be applied by instructed personnel.
- The power head emits strong magnetic radiation at 60 kHz to a distance of 20 cm. Therefore persons with cardiac **pacemakers** should **not work** with this device!
- Magnetic data storage media should be kept in a distance of at least 3m from the power head to avoid data loss. The same is valid for electromagnetic sensitive parts, devices and systems.
- Do **not place** the power head in the switched-on state **on metallic objects**, because this results in eddy currents, which could overload the device and strongly heat up small objects. In addition, the probe could be destroyed!
- No metallic objects, other than the disc-type coil, should be located in the air gap of the power head. The same applies to metallic parts within a radius of up to 15–20 mm in all directions.
- Do not use damaged or faulty cables!
- Never touch in the area between shaft and inductive head, the rotating shaft itself or rotor electronic contacts during operation!
- This is a “Class A” system suitable for operation in a laboratory or industrial environment. The system can cause electromagnetic interference when used in residential areas or environments. In this case the operator is responsible for establishing protective procedures.

Special two half ring housing for on of shaft mounting



T1-PCM-STG

Strain gage: Full and 1/2 bridge $\geq 350 \text{ Ohm}$,

Excitation: 4 VDC (fixed)

Gain: 250 - 500; 1000; 2000 (selectable by jumper!)

AZ: Auto Zero calibration (via AZ button from receiver side)

Analog signal bandwidth: 0 - 1200 Hz (-3 dB)

Operating temperature: - 40 to + 85 °C

Resolution 16bit

Scanning rate 6.41 kHz

Static acceleration: up to 3000g

Powering: Inductive

Housing: splash-water resistant IP65 (except the connector pins)

18 Windings CUL 0.5 or 0.63mm

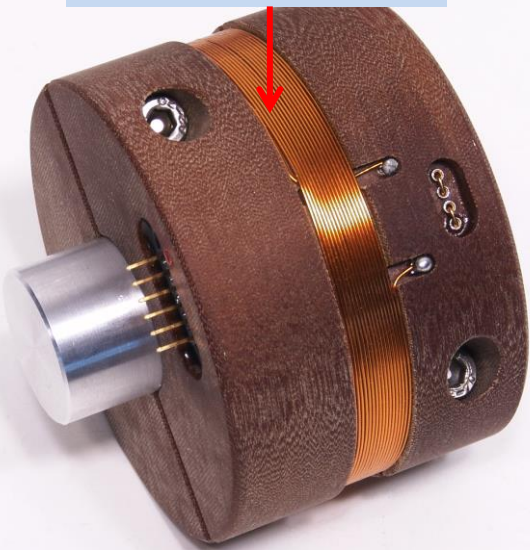

Full-Bridge

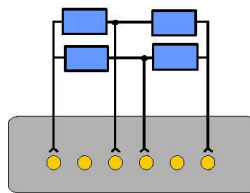

• EXC 4V
1/2
-IN
+IN
GND
GND

Half-Bridge

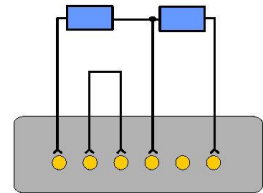

• EXC 4V
1/2
-IN
+IN
GND
GND

We recommend soldering the jumper!

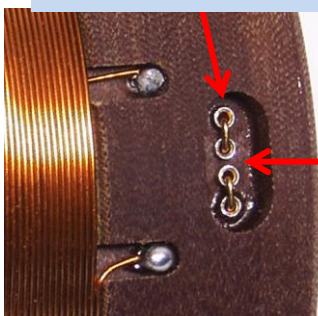

Restart the system after gain setting!!!

(Power OFF/ON)

A new Auto Zero at the decoder is requirement!

Gain 250	Gain 500	Gain 1000	Gain 2000
●	●	●	●
●	●	●	●
●	—	●	●
●	—	●	—
●	●	—	—
●	—	—	—



Technical Data Transmitting Part:

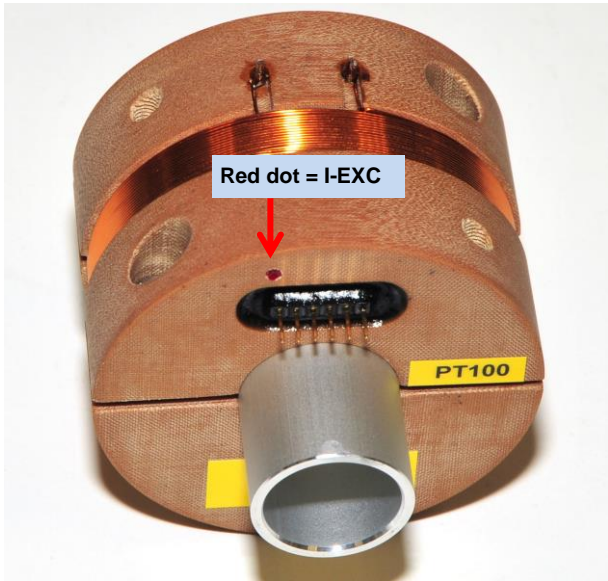

T1-PCM-Pt100

Pt100 thermo sensor
 Measurement range -50 to 250°C or -50 to 500°C (specify at order!)
 Analog signal bandwidth: 0 - 10 Hz (-3 dB)
 Operating temperature: - 40 to + 85 °C
 Resolution 16bit
 Scanning rate 6.41 kHz
 Static acceleration: up to 3000g
 Powering: inductive
 Housing: splash-water resistant IP65 (except the connector pins)

4-Wire

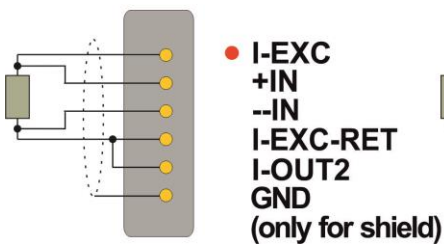

3-Wire

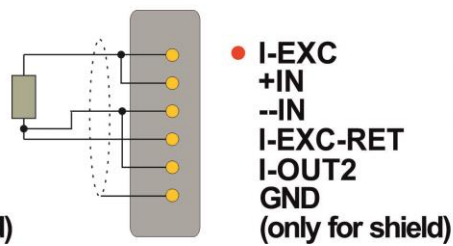

2-Wire

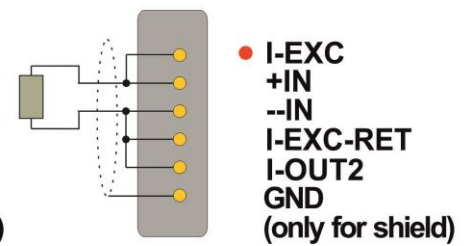

Special two half ring housing for on of shaft mounting

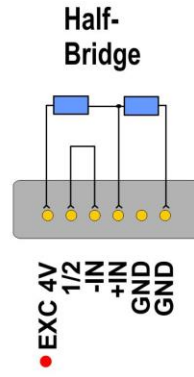
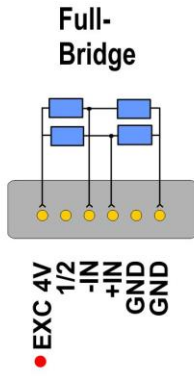
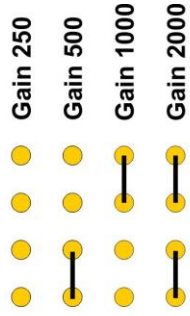

T1-PCM-STG embeddet in epoxy resin

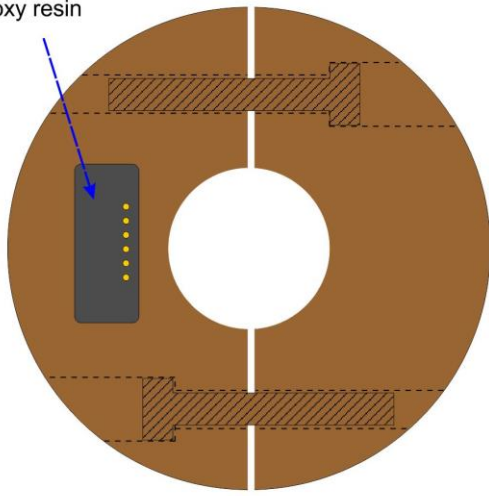

Material:

PF CC 201 IEC 60893 or Hgw 2082 DIN 7735
(Special phenolic resin cotton fabric)

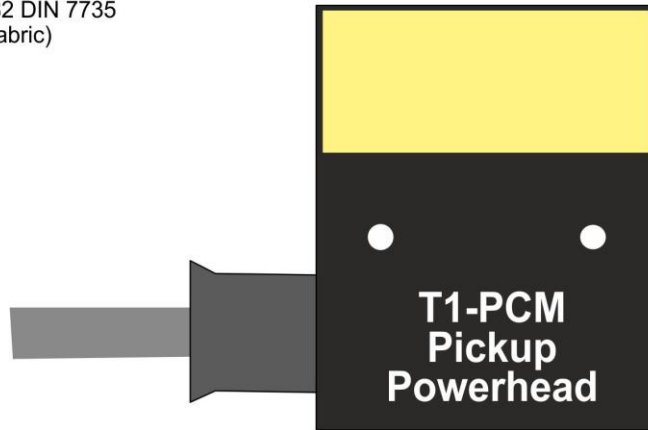
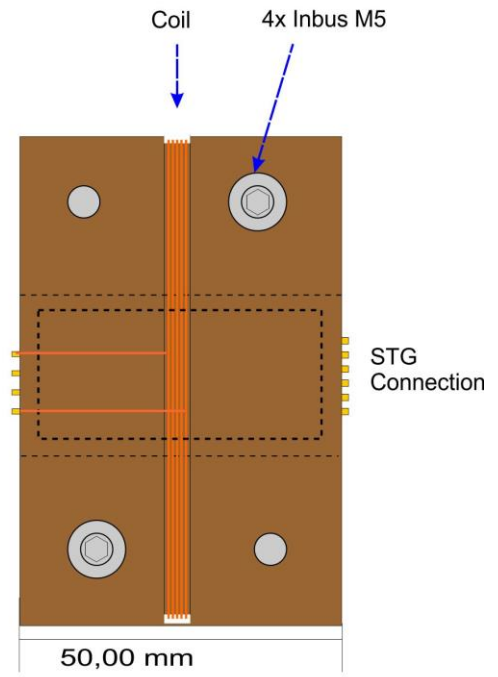

Special housing for end of shaft mounting
Wire connection:

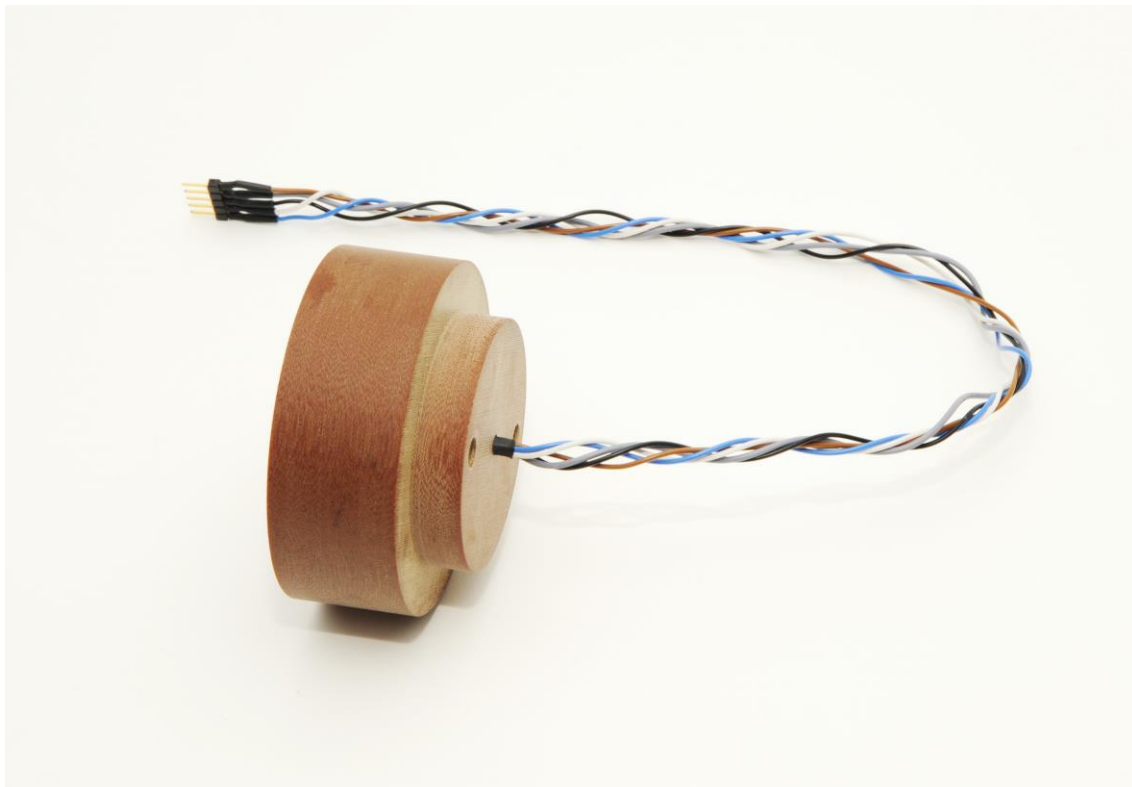

EXC	brown	4V bridge excitation
1/2	gray	1/2 bridge competition
-IN	black	Signal --
+IN	white	Signal +
GND	blue	Ground signal

Special housing for end of shaft mounting Head position

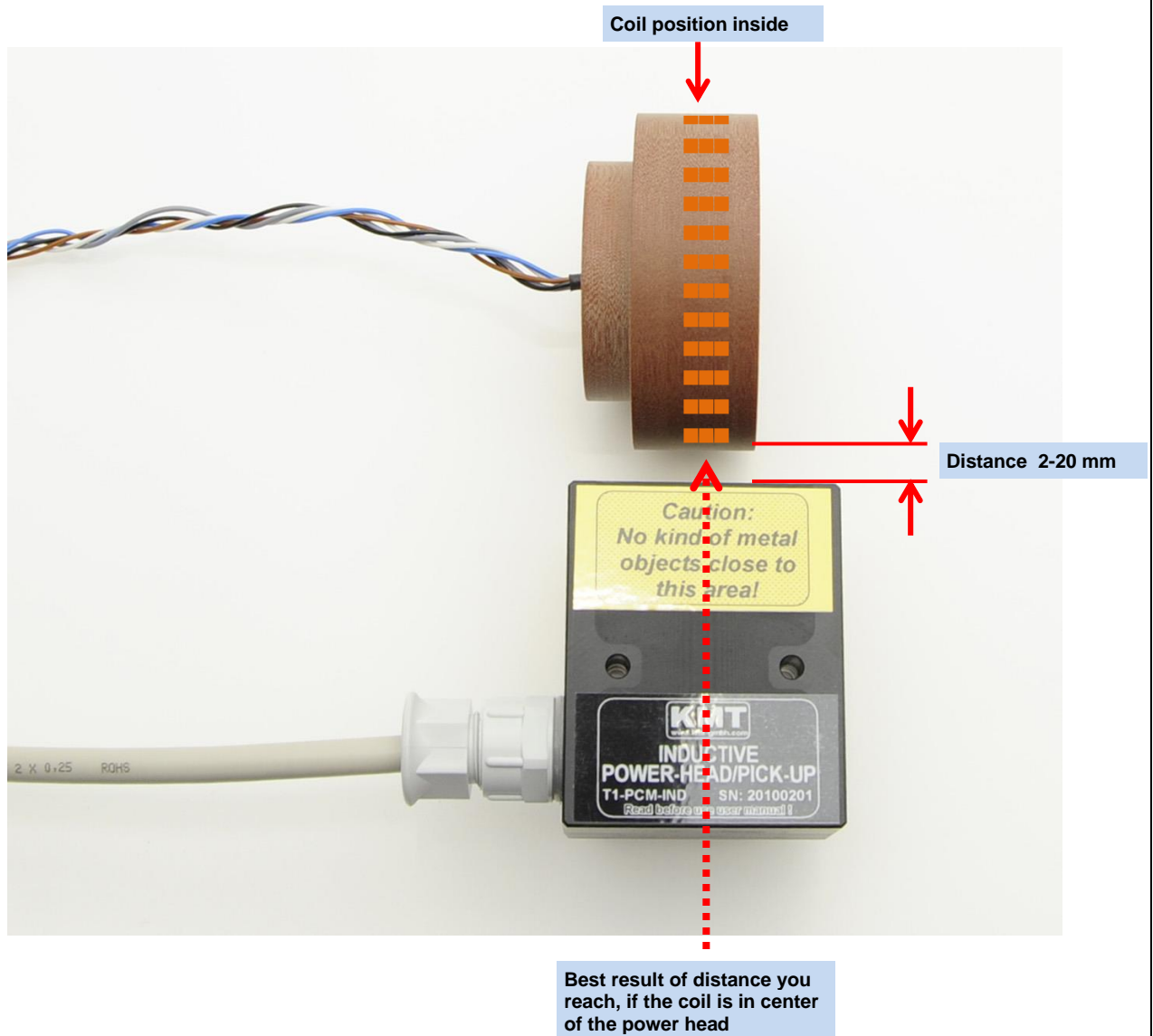

Special housing for end of shaft mounting

Draw:

T1-PCM-STG Module integrated in a special housing for end of shaft mounting, max. 3000 RPM

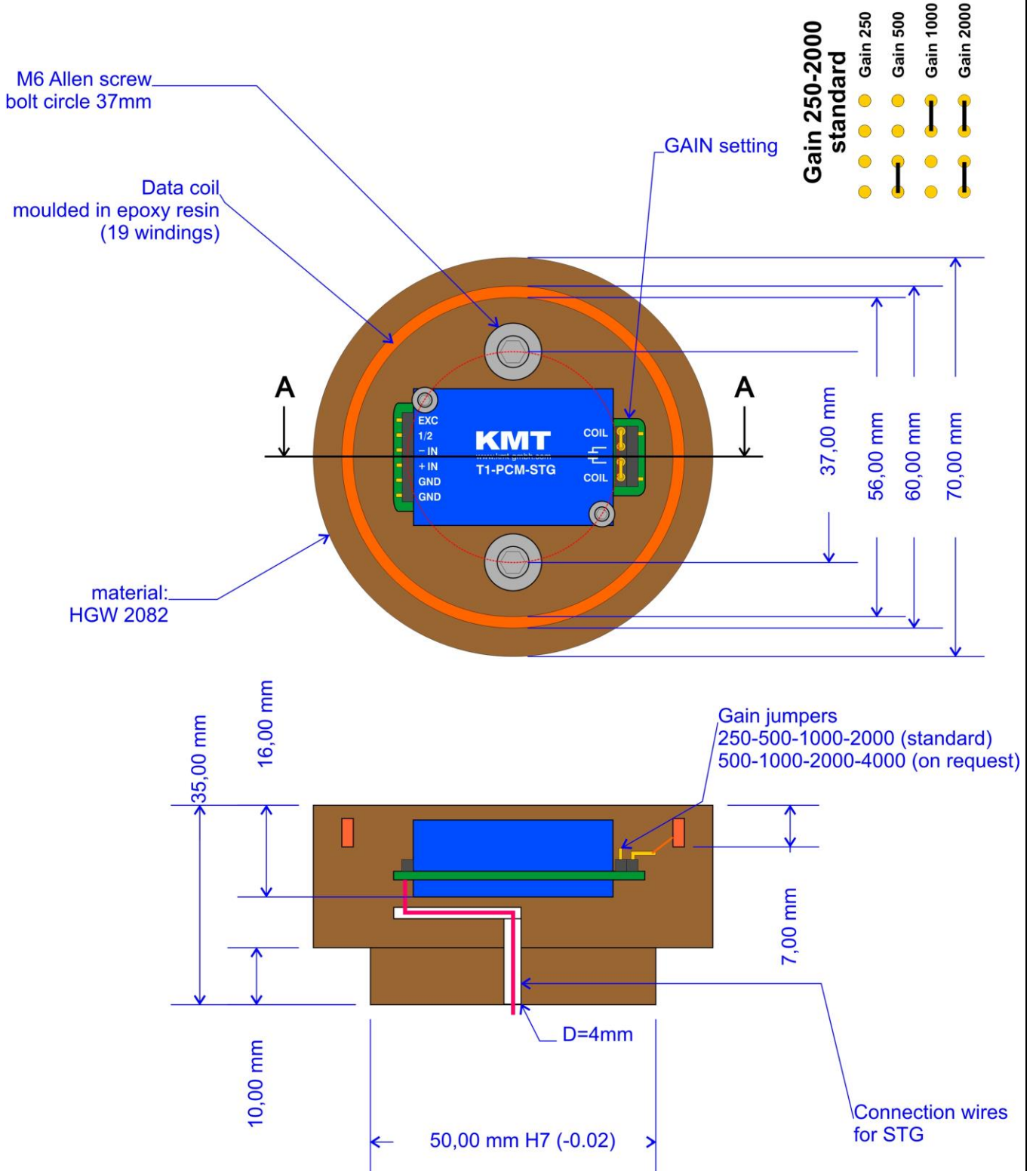

Konformitätserklärung

Declaration of Conformity
Déclaration de Conformité

Wir
We
Nous

KMT - Kraus Messtechnik GmbH

Anschrift
Address
Adress

Gewerbering 9, D-83624 Otterfing, Germany

erklären in alleiniger Verantwortung, daß das Produkt
declare under our sole responsibility, that the product
déclarons sous notre seule responsabilité, que le produit

Bezeichnung
Name
Nom

Messdatenübertragungssystem

Typ,Modell,Artikel-Nr., Größe
Type,Model, Article No.,Taille
Type, Modèle, Mo.d'Article,Taille

T1-PCM-IND, T1-PCM-BATT

mit den Anforderungen der Normen und Richtlinien
fulfills the requirements of the standard and regulations of the Directive
satisfait aux exigences des normes et directives

Elektromagnetische Verträglichkeit EMV / EMC

DIN EN 61000-6-2; VDE 0839-6-2:2006-03 Elektromagnetische Verträglichkeit (EMV) - Teil 6-2:
Fachgrundnormen - Störfestigkeit für Industriebereiche (IEC 61000-6-2:2005); EN 61000-6-2:2005
DIN EN 61000-6-4; VDE 0839-6-4:2011-09 Elektromagnetische Verträglichkeit (EMV)
Teil 6-4: Fachgrundnormen - Störaussendung für Industriebereiche
(IEC 61000-6-4:2006 + A1:2010); EN 61000-6-4:2007 + A1:2011

und den angezogenen Prüfberichten übereinstimmt und damit den Bestimmungen entspricht.
and the taken test reports and therefore corresponds to the regulations of the Directive
et les rapports d'essais notifiés et, ainsi, correspond aux règlements de la Directive.

Otterfing, 12.04.20017

Martin Kraus



KMT Kraus Messtechnik GmbH
D-83624 Otterfing - Gewerbering 9
Tel. 08024-48737 Fax 08024-5532
www.kmt-telemetry.com



Ort und Datum der Ausstellung
Place and Date of Issue
Lieu et date d'établissement

Name und Unterschrift des Befugten
Name and Signature of authorized person
Nom et signature de la personne autorisée